

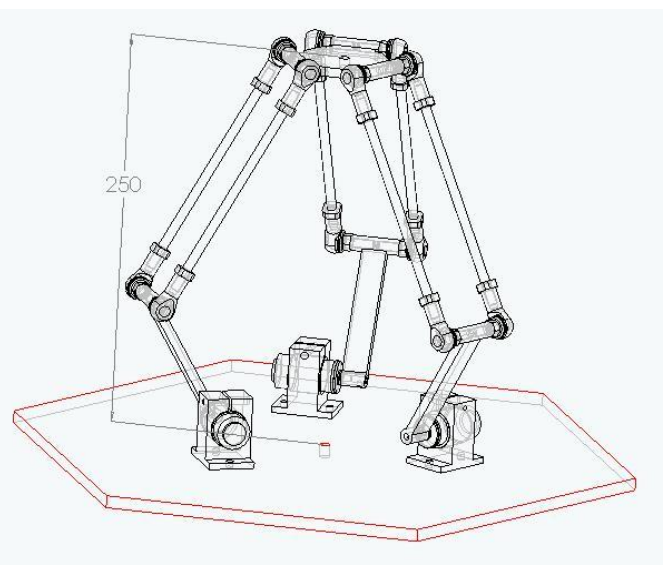

Part number:

**DPL-100A**

<b>Delta Robot:</b>	3 linear axis X, Y and Z
<b>Travel range:</b>	150mm in X,Y and 200mm in Z
<b>Motor type:</b>	DC Gerahead Servo
<b>Motor Voltages:</b>	9 -30V DC
<b>Motor current:</b>	1.5A / motor
<b>Encoder:</b>	Optical
<b>Gear head:</b>	Planetary
<b>Moving platform:</b>	Aluminum anodized
<b>Yaw/Pitch angle:</b>	Not specified
<b>Positioning error:</b>	1.2mm
<b>Maximum rated speed:</b>	25mm/s
<b>Maximum normal load:</b>	5N
<b>Index referencing:</b>	Optional "Home" switch
<b>Recommended controller:</b>	<b>DCX-300C</b> <small>RoHS</small>
<b>Learning function:</b>	Optional up to 20 positions

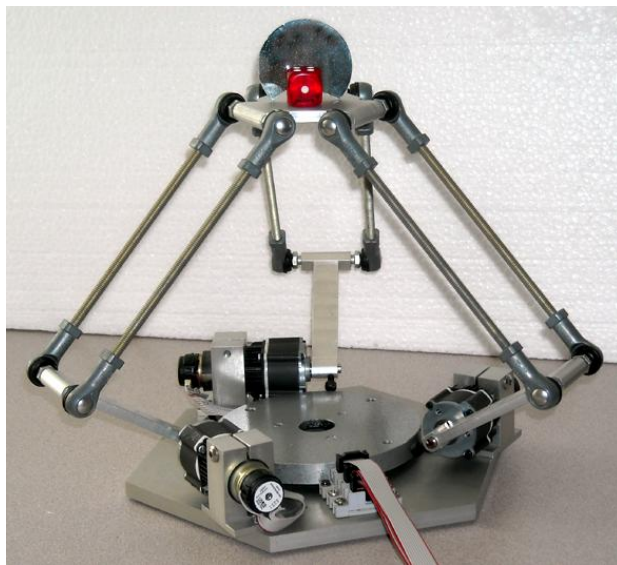

DPL-100

- The Delta robot **DPL-100** series is characterized by speed and precision, which is necessary for demanding applications.
- Due to its suitability for continuous operation, it is also an appropriate choice for industrial applications.
- The robot can operate as shown or hanging upside down in which case the backlash is compensated by the preload exerted by the gravitational force.  
All aluminum parts have a top quality clear anodized protective coating.